

240VAC Powered, 240vac starts/reset & 5-25VDC Pulse Outputs

Model: -1A-2A-3C

FEATURES

- Up to 4 Dual-Channel Modules (DCMs) can be mounted on Motherboard, for the creation of a 2, 4, 6, or 8 channel unit.
- All parameters and entries are fully programmable via a plug-in hand held keypad.
- Pulse Comparator for optional Dual Flowmeter system.
- **V1.8 software: can de-select the comparator function, so that each channel shows the reading from one flowmeter only.**
- Dual Display Counters for each channel (for Comparator function).
- Input Pulse scalable for use with most types of Flowmeters.
- All display readouts in Litres to 3 decimal places, with instantaneous flowrate display reading.
- Accumulated batch totals (grand totals) for inventory records.
- Initial Start and Pulsefail Safety
- Low and High Flow range settings. Pulsefail Safety safeguards against exceeding flowmeter operating ranges.
- Maximum pulse output frequency alarm, for PLC input safety.
- Maximum Batch Limit Safety.
- Output Pulse Division to PLC/Computer scalable.
- 240 VAC powered (Use atleast a 2.5 Amps to power the unit)
- **24-240 vac starts and Master Reset controls, with 5-24VDC pulse output switching to PLC inputs.**
- Manual Batch facility, with Disable option.
- Master Audible alarm function,
- Alarm condition for leaky check valves (back flow).



ME2008-8-1A-2A-3C

Simultaneous batching of all 8-channels without any sequencing requirements of starts.

INTRODUCTION

The ME2008 is a microprocessor-based batch safety interface card for management of flowmetering admixture liquids in the concrete production industries. Its design is at the request and requirement of suppliers/producers/users of construction chemical products. The software incorporates safety features designed to cover, detect and warn for most flowmetering faults during/after the batch cycle, making the flowmetering system one of the safest in the world. The ME2008 can be used with a wide range of signal output flowmeters in conjunction with a range of PLC/Computer auto batch systems. All message status functions are displayed at all times, and the settings are easily retrieved and displayed. This helps make the ME2008 very user-friendly. The unit consists of:

- 1x **MOTHERBOARD** (24VDC powered) complete with 8 individual pushbuttons for manual batch facility, along with a pushbutton to select (or scroll) menu functions, a button for manual reset of batch displays and a button for alarm muting (can be disabled), all enclosed in a wall/panel mount ABS enclosure.
- 1,2,3 or 4x **DUAL CHANNEL MODULE (DCM) plugable PCBs** with dual-line LCD displays with backlight.
- 1x Hand held **plug-in programmer** for entering parameters.

OPERATION

Flowmeters of various sizes can be connected to the inputs. ME2008 accepts 8 external start commands. It delivers DC low voltage (sink or source 5 to 24 VDC) pulses to a PLC/computer with optical isolation. The ME2008 controls and manages up to 8 admixture products / 8 flowmeters (or up to 16 flow meters, 2 per channel, if you utilize the comparator function).

ME2008 can be used as a manual pushbutton batch controller unit. This function can be disabled via a link for computer control only start operations. The handheld plug-in programmer is unplugged after all parameters have been setup.

When the PLC/Computer system starts, the ME2008 begins counting in millilitres, and the output pulses are re-transmitted to the PLC/Computer input at the divided pulse value. A sophisticated safety management watches for any malfunction in the system, flowmeter or batch computer during the batch cycle. If a fault is detected, the ME2008 will override and shutdown the faulty channel, and give alarm warnings. The computer provides auto reset at completion of batch, resetting all counters. All activity is logged on grand totalisers for inventory management data. Also included is an instantaneous flowrate reading per channel, which indicates if the operating range of each flowmeter is exceeded.

INSTALLATION

Find an appropriate position to mount the ME2008 housing box, preferably within visual distance to operator. Using flexible wires, wire the ME2008 according to the diagrams:

- Figure 2. Full Schematic Diagram, on page 3
- Figure 3. Motherboard Wiring Diagram, on page 4
- Figure 4. Dual Channel Module (DCM), on page 4
- **Error! Reference source not found.**, on page 5

The normal order of connections is:

1. On the motherboard (see page 3), connect 240VAC supply to computer supply to reduce industrial noise (**X5 plug**, which is a 4-pin green-coloured plug). **L is active load, N is neutral, E is earth.**
2. Connect the computer's 240VAC Master Reset control signal to the top pin only (marked RST) of the **Motherboard X1 plug** (3-pin green coloured plug). (see Figure 3, Page 4)
3. Using shielded cable, connect flowmeters (with no earthing on the bodies of the flowmeters) to the ME2008's Dual Channel Modules (DCMs), as shown in Figure 4 and **Error! Reference source not found.** (pages 4 and 5) . Use minimum 2-core shielded cable per flowmeter to the DCM's **X4 plug** (6-pin, green coloured). If using one flowmeter per channel, use **Pulse 1A** and **Pulse 2A**, and **+12 VDC** and **S (Shield) = 0.V**, which are both common for flowmeters. (1 x 6pin green plug connector per channel).

NOTE: **B** pulse inputs are used for only dual flowmeters per channel for Comparator function.

If NOT using comparator dual flowmeters, then bridge pulse 1A to pulse 1B, and bridge pulse 2A to 2B.

If equip with software V1.8 or higher then set "Diff. Channels" = "1" and NO need to bridge out. (see Page 7,no.13)

4. (a) For first channel: (see Figure 2 page 3 and Fig.4 page 4 and Fig.5 page 5).
 - connect the **240 VAC START** signal from PLC/Computer to the **DCM X2 plug** (6-pin, black coloured), pin **S1**. To the **black Opto**.
 - connect the **240 VAC ACTIVE** side of the contactor coil to **DCM X2 plug**, pin **R1**. Connect neutral side of contactor to the AC power supply of the ME2008
- (b) Similarly connect for the second channel, using **DCM X2 plug**, pins **S2** , and **R2**
- (c) **For low voltage DC (5 - 24 VDC) pulse output** to the PLC/Computer, connect the **DCM X3 plug** (4-pin white coloured), **C1 = Collector, E1 = Emitter** for Channel 1 and then **c2/e2** for Channel 2 to the PLC/Computer's pulse input. (see Figure 4,Page 4 and Figure 5,Page 5).

REPEAT Same procedures for upto all 4 modules

5. As shown in Figure 5 on page 5, for DC control logic the DCM is fitted with **4N33 5 - 24VDC OPTOs** marked as U3 and U4. (note the placing position.)
6. **To disable the front MANUAL batch pushbuttons**, remove link **LK1** located on motherboard near the Alarm buzzer (see Figure 3 on page 4). This will avoid misuse of manual starts. The other manual functions "Select", "Mute" and "Reset" will be still fully functional. Plug-in LK1 to re-activate manual batch functions.
7. The entry of program parameter data is achieved with a 4-button keypad programmer (see Figure 1 Figure 1. Programmer) that is plugged onto the 5-pin inline Data Entry Plug-In plug rail located on each Dual Channel Module (as shown in Figure 4 on page 4). The programmer plug is keyed so that it can only be plugged in the correct way.



Figure 1. Programmer

Each Dual Channel Module (DCM) is programmed one at a time. Plug the Programmer into the DCM to be programmed (the programming plug location is shown in Figure 4 on page 4).

If equipped with external programming panel (8CAT5E for 8 channel), connect the programmer CAT5E plug to the external panel with marked channels 1 to 8 (2 channels per terminal). See as above

To start programming, push either arrow button (→ ←) **on the Programmer**. Cursor (digit) will flash on the DCM display. Push UP or DOWN to change numeric values. Push arrows to scroll through the individual numeric settings. Once programming is completed, push either arrow button (→ ←) until no digits are blinking, data is now entered into memory. Unplug the Programmer, then plug it in to the next module and repeat data entry to programme another module.

See OPERATING INSTRUCTIONS on page 5, for program menu display and description. Note: For guide to entering complete data safely each flowmeter type, see Flowmeters Data Guide on page 11.

Neutral
Active Starts 240vac

Figure 2. Motherboard Wiring Diagram,
240vac supply, starts and Master reset.
5-24VDC pulse outputs.

Fig. 2

Figure 3. Motherboard Wiring Diagram, X1 and X5 plugs

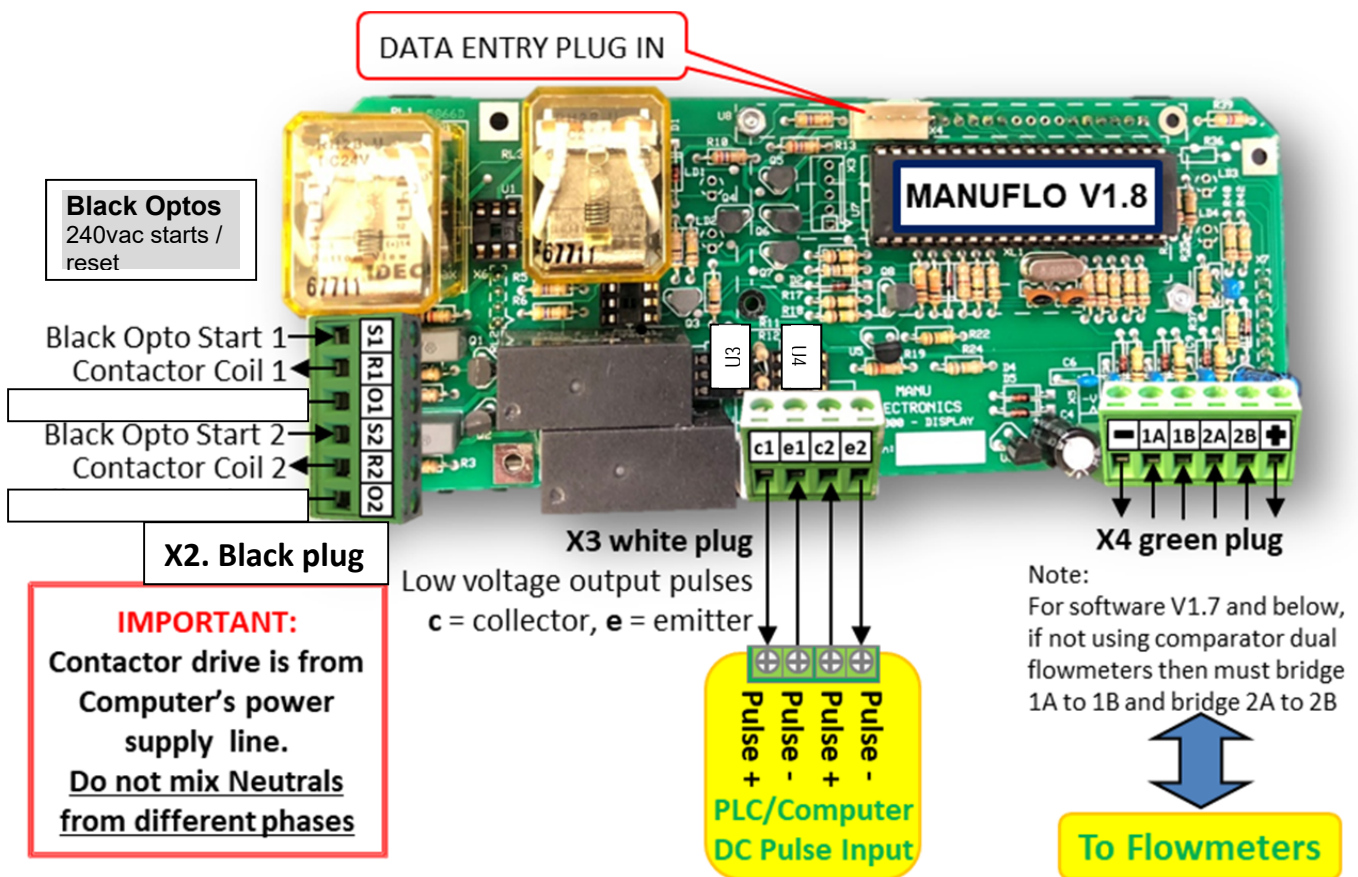
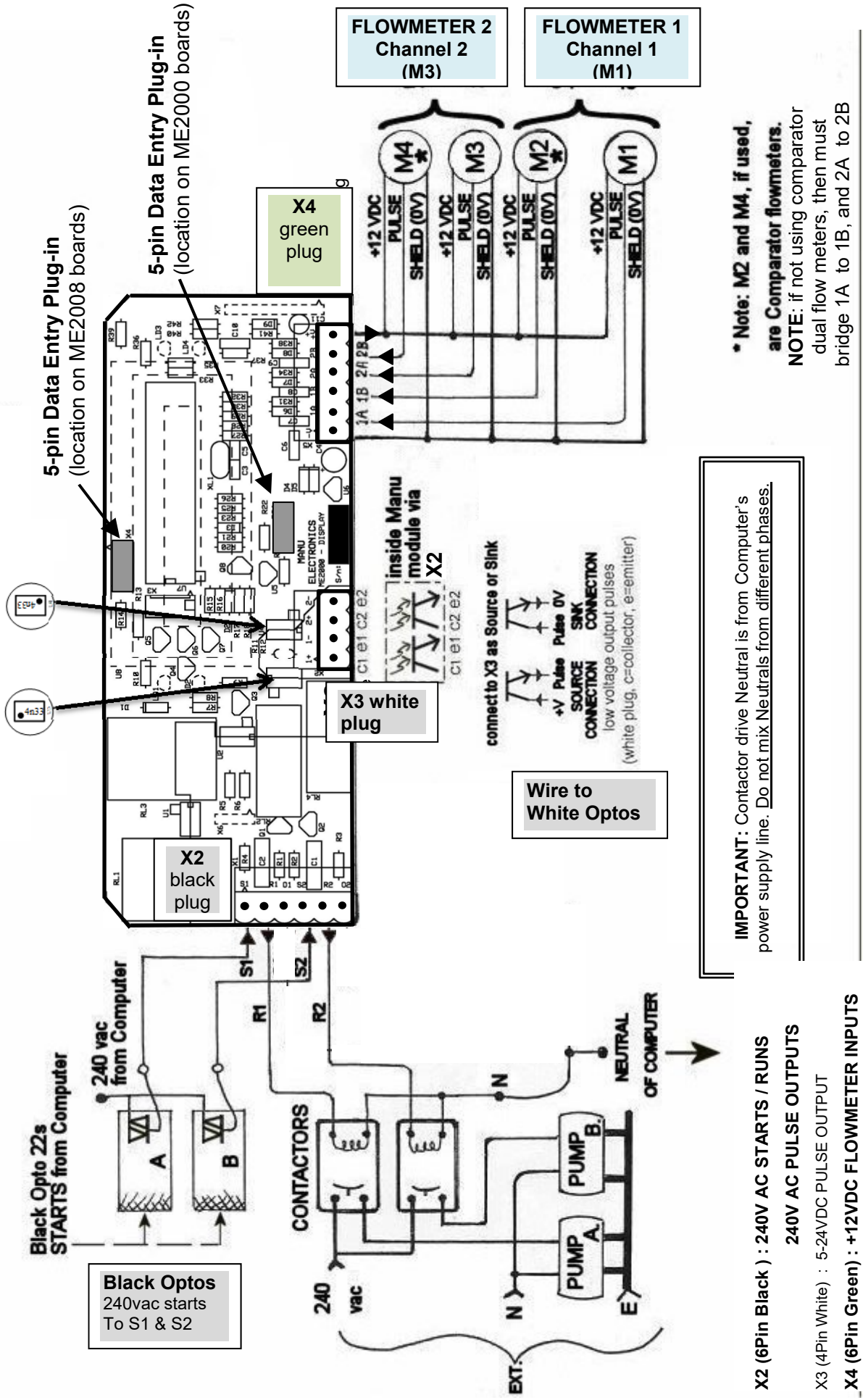

Figure 4. Dual Channel Module (DCM)

Note: Dual Channel Modules for the ME2008 and ME2000 have slightly different component layouts (the most obvious is the Data Entry Plug-in location) but the boards are functionally equivalent and are interchangeable.

Fig. 5



240VAC option shown
wired with PLC I/Os, flowmeters, pumps.

Figure 3. Dual Channel Module (DCM) wiring

*** Note: M2 and M4, if used, are Comparator flowmeters.**
NOTE: if not using comparator dual flow meters, then must bridge 1A to 1B, and 2A to 2B

IMPORTANT: Contactor drive Neutral is from Computer's power supply line. Do not mix Neutrals from different phases.

- X2 (6Pin Black) : 240V AC STARTS / RUNS
- 240V AC PULSE OUTPUTS
- X3 (4Pin White) : 5-24VDC PULSE OUTPUT
- X4 (6Pin Green) : +12VDC FLOWMETER INPUTS

ME2008 1A-2A START/RUN/RESET WIRING DIAGRAM

Fig. 6

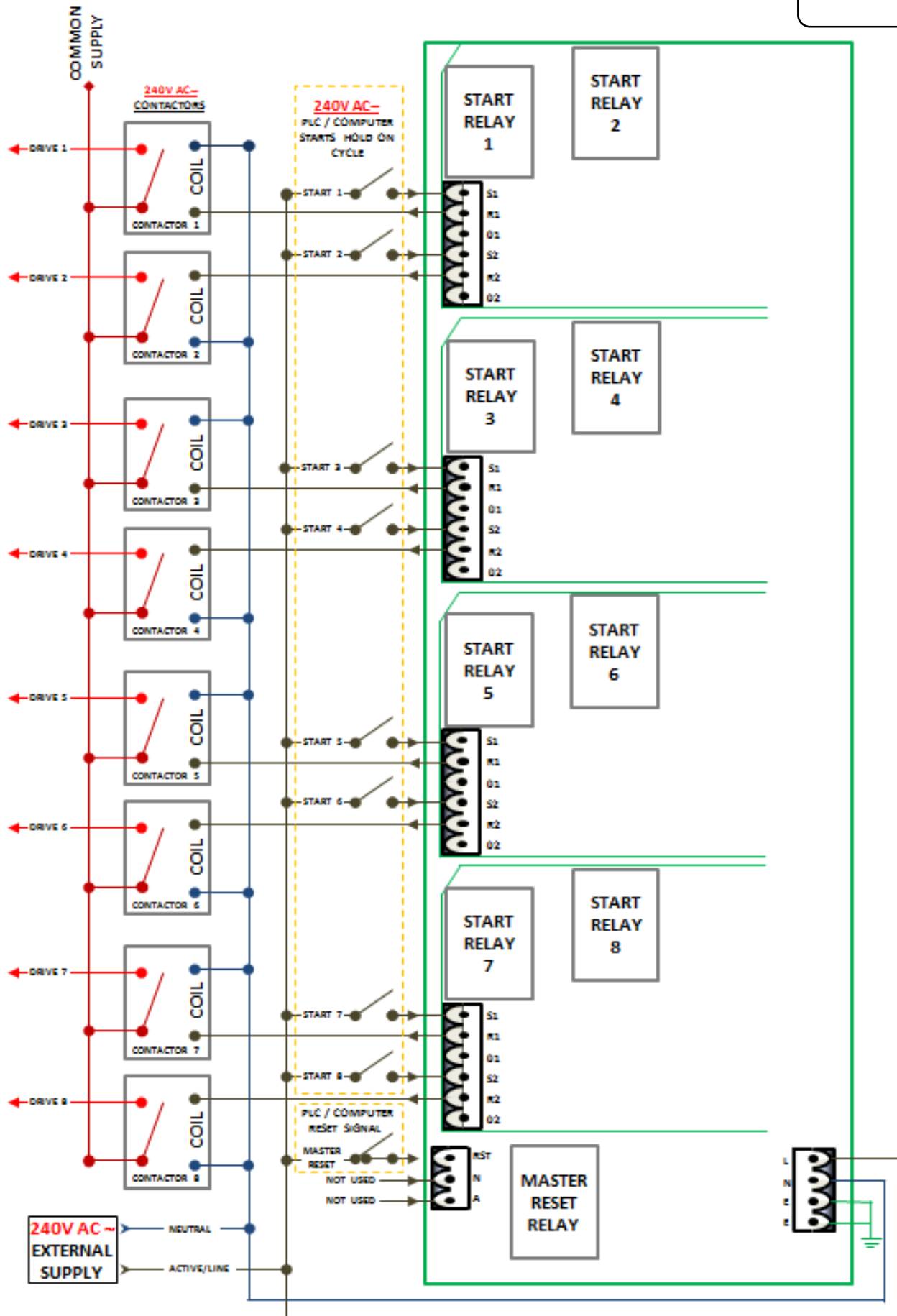

OPERATING INSTRUCTIONS

* Switch on power to the ME2000 interface safety unit. * Scroll through the settings by pressing SELECT. Refer to the Display Diagram below for procedures and settings of required parameters. * See "Flowmeter Data Guide" on page 11 for recommended data for each flowmeter type/size characteristics/flowrates.

ME2008 Display Menu

⇒ Power On:

MANU ELECTRONICS
ME2008 V1.8



⇒ 1. Push Select:

000.000 000.000
000.000 000.000

Batching function display in "LITRES" to 3 decimal places. At anytime you can skip functions and return to normal by pushing RESET (You cannot reset while pumping is in progress).

⇒ 2. Push Select:

Flow (l/s)
000.000 000.000

Flow Rate Function in Litres/second (to 3 decimal places).

⇒ 3. Push Select:

Total (l)
000000 000000

Grand Total accumulation.
To reset: push 2 buttons at once on 4-button programmer.

⇒ 4. Push Select:

Input (p/l)
1000.00 1000.00

K-factor / Calibration:
sets pulse input value per litre, according to flowmeter used e.g. MES20 1000pulses/litre, MES25 0555pulses/litre.

⇒ 5. Push Select:

Output (l/p)
00.010 00.010

Pulse Output Volume Value (Litres /pulse).
Sets division of output pulses to suit computer/PLC.
Resolution from 1ml. Example shows 10ml.
See also "Program Record Sheet" (page 12).

⇒ 6. Push Select:

Min. Flow (l/s)
00.010 00.010

Minimum flowrate
(set this according to flowmeters' recommended minimum). Pump will be stopped if the flowrate falls below this value.
Previously known as **Pulsefail** in ME697, ME995/188 units.

⇒ 7. Push Select:

Max. Flow (l/s)	
01.000	01.000

Maximum flowrate
(set this according to flowmeters' recommended maximum). Pump will be stopped if the flowrate exceeds this value.

⇒ 8. Push Select:

Dose Limit (l)	
010.000	010.000

Sets maximum acceptable limit per batch (overrides computer selection). If limit is reached, pump is stopped and "Overdose" warning will be displayed.

⇒ 9. Push Select:

Max Backflow (l)	
000.100	000.100

The **Backflow** function raises an alert if the check (non-return) valves leak. Set to the desired maximum allowance of backflow.

⇒ 10. Push Select:

Difference (%)	
05.0	05.0

COMPARATOR (5% = $\pm 2.5\%$) **Optional Function.**
This function is used to compare 2 flowmeters in series. If the flowmeters differ by more than the allowed percentage, the pump will be stopped and an alarm triggered.

⇒ 11. Push Select:

Start Delay (s)	
02.0	02.0

Start Delay is the time (in seconds) allowed for pump to start before the Pulse Fail safeties activate. After the Start Delay period, the safeties will shut down the pump drive if no flowmeter pulses are received.

⇒ 12. Push Select:

Stop Delay (s)	
02.0	02.0

Stop Delay is the time (in seconds) allowed for the pump to settle after stopping, before back flow detection commences.

⇒ 13. Push Select: **(Only available from software Version 1.8)**

Diff. channels	
1	1

Difference Channels : enables/disables the comparator function, for each channel of the two-channel module.
When value is "1", the comparator is disabled, and the display for that channel shows the reading from the one flowmeter installed.
When value is set to "2", the comparator is enabled, and the display for that channel shows the readings of two flowmeters installed in series.

⇒ 14. Push Select:

Max Out Rate(Hz) 0040
--

Max Out Rate is the maximum allowed rate of output pulses to the PLC/computer's input. If the maximum is exceeded, then the drive to pump contactors stops, the ME2008 stored buffered memory sends the extra pulses to the PLC/Computer's DC White Optos (under the 40 Hz max. input rate) or to low scanrate systems.

This safeguards against any overdoses which could occur if PLC does not capture all incoming pulses.

NOTE:

(1) DO NOT SET THE MAX OUT RATE UNNECESSARILY HIGH, as this will affect the duty cycle of the pulses (i.e. will narrow the pulse width) which may make it difficult for the receiving PLC to detect the pulses.

Example: if the receiving PLC can only detect pulses at a rate up to 40 Hz, then set MAX OUT RATE to 40 and not to 100.

(2) Extra pulses received (above the allowed rate) represent actual extra volume measured by the flowmeter and ME2008, but which would have otherwise not been fully counted by the PLC/Computer system. (This situation is different to actual "inflight overflow", where a DEDUCT value must be programmed in the computer system to stop the pump earlier).

IMPORTANT: Some PLC/Computers that accept DC input pulses via "White" optos have a pulse input frequency limit of 40 Hz, so for the ME2008 to protect such systems and prevent overdose, set values in the ME2008:

* MAX OUT RATE to 40Hz or less for DC type; and

* OUTPUT (LITRES/PULSE) to a value so that, at your maximum operating flowrate, pulses to PLC/Computer will not exceed 40Hz.

e.g. if your operating flowrate is 60 Litres/minute, and you set OUTPUT (LITRES/PULSE) = 0.050 (i.e. 50 mls/pulse), the ME2008 will output 20 pulses/second (i.e. < 20Hz) to the PLC/Computer well below the 40Hz. Max pulse rate.

⇒ 15. Push Select:

MANU ELECTRONICS ME2008 V1.8

Returns to intro display.

Note: V1.9 software is for Water channel options

⇒ 16. Push Reset:

000.000 000.000 000.000 000.000
--

Returns to the Batch function.
Display is in "LITRES" to 3 decimal places.

WARNING

Only after all products are batched, should totals be reset (does not affect accumulated totals).

All ME2000/2008 should be upgraded with the latest v1.8 software. Micro chips can be purchased & plugged-in.

Before you leave the plant, you must take a VOLUMETRIC calibration of quantity dispensed and cross-reference with ME2008 readings !!!

ALARM SAFETY STATUS

If any of the safety features are triggered, the relevant alarm will come on. The Display will indicate status of the channel that is in alarm condition (see message explanations on page 11). In this case, as a precaution the ME2008 will shut down pump drive of the faulty channel only, allowing for further examination of the problem.

SAFETY PROCEDURE IN EXAMINING THE PROBLEM

If the alarm comes on, **DO NOT** push RESET immediately - just push MUTE to silence alarm, then observe display and take note of batch readings and alarm message. Address the problem if possible.

WAIT for other channels to complete batch, then push RESET to be ready for the next batch.

✓ See **Troubleshooting Guide** on pages 12 – 13.

ME2008 - SPECIFICATIONS

Display	One 2x16 character dot matrix backlit display per Dual Channel Module (DCM).
Motherboard	Accepts up to 4 plug-in Dual Channel Modules.
Power Supply	240 vac via Motherboard X5 plug green . (See options guide for other voltages)
Current Draw	1.5 Amps max. (≥ 2.5amps Power Supply Recommended)
Supply to Flowmeters	12 VDC (10mA per flowmeter), via DCM X4 green plug .
Pulse Inputs	NPN sink pulse or Reed Switch pulses via DCM X4 plug green , 2 flowmeters per module (4 for comparator). Input calibration to 3 decimal places. Most types of flowmeters can be connected and calibrated.
Input count speed	2 kHz maximum.
Output pulses to computer	5-25 VDC sink/source pulse via 4N33 open collector opto (DCM X3 white plug). (7500V rms surge protection). All pulses are divided via "Output Pulse Value" calibrator.
Computer starts/runs	240V AC via DCM X2 plugs black .
Computer reset	240V AC via Motherboard X1 plug (green) .
Manual Batch Commands	Starts: 8 momentary-hold push buttons for each channel (when link enabled). Master Reset: 1 pushbutton. MUTE: 1 pushbutton. SELECT: 1 pushbutton.
LED functions	"Output" (divided pulses) indicated via flashing LEDs "Run" (manual starts/computer starts) indicated via illuminated LEDs.
Power ON/OFF	Via "Power" switch.
Wiring/Connection	Wired via cable mount plugs. DCM connected via mated plugs, allows unplugging of PCBs for easy replacement.
Fuse	2 Amps. Fuse holder on motherboard. 20x5mm type
Enclosure & Dimensions	IP58 ABS lid/box. Size: 310mm L x 245mm W x 140mm D.
Weight (with 3 modules)	2.6 kg

Display Functions

Operation	Via plug-in 4-button hand-held programmer.	
Volume displayed	In Litres, to 3 decimal places (smallest increment is 1 millilitre).	
Flowrate display	In Litres per Second (l/s), to 3 decimal places.	
Grand Total	In total Litres (l),	
Input calibration	Pulses per Litre, to 9999.99	(Default:1000.00 = MES20)
Output pulse value	From 00.001 to 99.999 Litres per pulse	(Default: CH1: 00.010, CH2-8: 00.100)
Min flowrate safety	From 00.001 to 99.999 Litres per second	(Default: CH1: 00.010, CH2-8: 00.400)
Max flowrate safety	Max. 99.999 Litres per second	(Default: 01.000 all channels)
Dose Limit	Max. 999.999 Litres per batch cycle	(Default: CH1: 010.000 CH2-8: 20.000)
Max Backflow	From 000.001 to 999.999 Litres	(Default: CH1: 000.100 CH2-8: 000.400)
Comparator difference	0.1 to 99.9%	(Default: 5.0% i.e. +/-2.5%)
Start Delay	0.1 to 99.9 seconds	(Default: 2.0)
Stop Delay	0.1 to 99.9 seconds	(Default: 2.0)
Diff. Channels	Arm/disarm difference function 1=off, 2=on	(Default: 1=off, 1 flowmeter only)
Max Output pulse rate	0001 to 9999 Hz	(Default: 14)
*Alarm Messages	Refer to Page 12 Troubleshooting Guide – Alarm Messages	

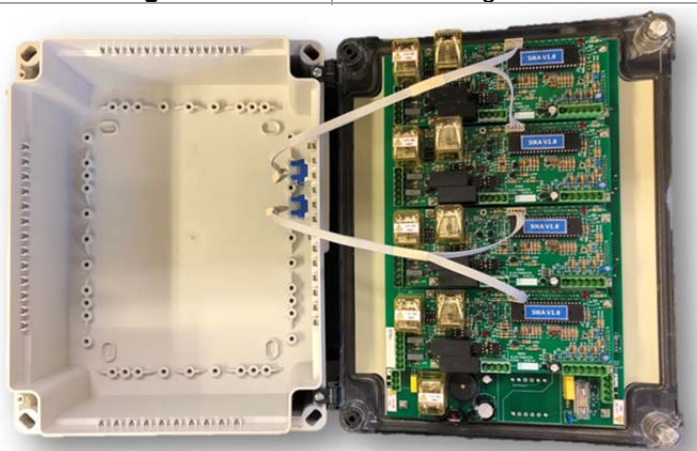

ME2008 8-channel unit, opened, with external 8CAT5e Programmer

FLOWMETER DATA GUIDE FOR ME2008 DATA ENTRY

ME2008 setup data for various flowmeters:

Set to 10-20%
of the usual
flowrate of
the installation.Set to 90% of the
specified maximum
flowrate of the
flowmeter.**Manu Flowmeters**

Model No	Description	Input pulses/Litre	Min. Flow Litres/sec	Max. Flow Litres/sec
MES20 (AEA)	20mm pulse flowmeter (low)	1000.00	00.010	01.000
MES20	20 mm pulse flowmeter	1000.00	00.100	01.100
MES25	25 mm pulse flowmeter	0552.00	00.150	01.800
MES32	32 mm pulse flowmeter	0261.00	00.200	03.000
MES40	40 mm pulse flowmeter	0116.00	00.300	05.000
MES20R	20mm reed pulse flowmeter	0061.00	00.100	01.100
AMM15	15mm magflow pulse meter	1000.00	00.050	01.000
AMM20	20mm magflow pulse meter	1000.00	00.100	01.600
AMM25	25mm magflow pulse meter	0500.00	00.100	03.200

BEST OUTPUT PULSE RESOLUTION VALUESwith MES flowmeters to DC input CommandBatch Computers

Model	Size	Pulse Output value	Max Safe Flowrate not to exceed computers Current DC digital input count limit speed of 35Hz (& flowmeter max) (set in Max. Out Rate) ↓		
MES20	20mm	10 mls per pulse	0.35 litres/sec.	21 litres/min.	35hz
"	"	20 mls per pulse	0.70 litres/sec	42 litres/min.	35hz
"	"	25 mls per pulse	0.875 litres/sec	52 litres/min.	35hz
"	"	30 mls per pulse	1.05 litres/sec	63 litres/min	35hz
"	"	40 mls per pulse	1.40 litres/sec	84 litres/min	35hz
"	"	50 mls per pulse	1.40 litres/sec	84 litres/min	35hz
MES25	25mm	40 mls per pulse	1.40 litres/sec	84 litres/min.	35hz
"	"	50 mls per pulse	1.75 litres/sec	105 litres/min.	35hz
MES32	32mm	100 mls per pulse	3.00 litres/sec	180 litres/min.	30hz
MES40	40mm	100 mls per pulse	4.00 litres/sec	240 litres/min.	35hz

NOTE: ME2000 can emit 1mls/1 pulse if PLC computer input cards have high speed input capability
(Output overrun is set to 35Hz to safeguard the system settings).

KMS/RMS ManuFlo and other Electromagnetic Flowmeters

15mm & 25mm = 100ppl. | 40mm & 50mm = 10ppl. See the ManuFlo RMS Datasheet for flowrates.

Many other types of flowmeters can be used with the ME2008.

Order Codes for ME2008

ME2008-6 6 channel unit (3 module) } then must also choose one option from
ME2008-8 8 channel unit (4 modules) } at least EACH of the following three groups:

(1) Power Supply	-1A	240 vac power supply
	-1B	110 vac power supply
	-1C	24 vac power supply
	-1D	24 VDC power supply
(2) Start Input/Output Drives & Master Reset (from PLC starts)	-2A	240 vac start/reset relay logic fitted.
	-2B	110 vac start/reset relay logic fitted.
	-2C	24 vac start/reset relay logic fitted.
	-2D	24 VDC start/reset relay logic fitted.
	-2E	12 VDC start/reset relay logic fitted. Negative switching.
(3) Pulse Output (to PLC input pulses)	-3A	240vac Moc3041 triac pulse output switching (only with '-1A' 240vac pwr supply option)
	-3B	Same ac voltage as for the start/reset option (i.e. 24vac or 110vac)
	-3C	5-30 VDC Open Collector pulse output. Suits CommandBatch / Jonel / other computers.
Other Options	-V1.8	Software version with option to disable comparator function (each channel has 1 counter per flowmeter instead of 2)
	-IR	Independent Resets for each 2-channel module in the ME2008.
	-USA	USA units (non-metric) e.g. Gallons.
	8CAT5E	4-way external panel, for programming up to 4 dual modules (includes HP-CAT5E)
Spares	HP-CAT5E	Programmer with CAT5E plug.
	HP	Spare hand-held plug-in keypad programming module.
	HK	Hinge Kit.

All other program parameters can be factory-entered or done via the plug-in programmer (see diagram above) onsite.

ME2008 - Program Record Sheet

Serial Number : _____ Date : _____
 ME2008 Part No. Config : _____ Software Version : _____
 Voltages : _____

Display in: Litres Gallons

		Channel							
		1	2	3	4	5	6	7	8
Flowmeter Model (part no.)									
K-FACTOR (CALIBRATION) If not known: Set input parameter to 1, then run liquid, divide volume by count = pulses per unit.									
Input Pulses	• per Litre								
	• per Gallon								
PULSE OUTPUT VOLUME VALUE TO PLC									
Output Pulses	• Litres/pulse								
	• Millitres/pulse								
MINIMUM FLOWRATE CUTOFF									
Min. flow	• Litres/sec								
	•								
MAXIMUM FLOWRATE CUTOFF									
Max. flow	• Litres/sec								
	•								
MAXIMUM BATCH LIMIT									
Dose Limit	• total Litres								
	•								
MAXIMUM BACKFLOW									
	• Litres								
	•								
Comparator difference %									
Start Delay (seconds)									
Stop Delay (seconds)									
Difference Selection: 1=1 flowmeter, 2 =2 flometers per channel									
Max Output Rate (Hz)									

Date Programmed : _____ Date Commissioned : _____
 By : _____ By : _____
 Comments : _____

ME2008 - Technical Guide

Lightning and Power Supply to ME2008

- The Power Supply must come from the computer supply, which should have lightning arrestors already fitted to its Uninterruptable Power Supply (UPS).
- Fitting a 0.03 to 0.1 μ F 250vac capacitor on the pump contactor coil (between pump drive of ME2008 and Neutral), helps eliminate any voltage spikes (see page 11).

STARTS DRIVES

Computer starts have Black Optos which are usually solid state optos. When computer starts, the Optos stay on ("240vac energized") for the duration of the batch cycle and turn off at completion of the batch cycle. When the optos turn off, sometimes a higher than normal residual leakage voltage is maintained e.g. 90 vac (so installers/maintainers must measure, on the batching computer, the leakage voltage, when a batch is NOT in progress, between each black Opto's start 240v Active and Neutral). This voltage is sometimes enough to keep ON relays that drive contactors or solenoid coils. If this occurs, fit a 12k Ω 5W resistor between the Start Drive and Neutral connections (see page 11).

Pulse Output

In software version V1.7, the pulse output drive to the PLC optos is kept low when there are no output pulses, to help prevent noise. In V1.8, is as above, but also with ability to select a single counter for each flowmeter (so no need to bridge 1A and 1B, etc). Any units with software versions at 1.6 or earlier, should have their modules returned to ManuFlo to be upgraded to V1.7 or V1.8.

TROUBLESHOOTING - BACKFLOW

In some installations with standard MES flowmeters, the ME2008 may count without batching being in progress, causing a "Back Flow" alarm.

- 1 Usually, this is due to the Non-Return Valve not closing, thus allowing backflow which results in counts as the liquid runs back thru the flowmeter (PD types).
Ensure that the Non-Return Valve is clean and operating correctly.
- 2 If Non-Return Valve is OK, then ensure that shielded cable is used. If cable is not shielded, then interference can be picked up and transmitted to the ME2008 which will interpret it as backflow.
- 3 If shielding is OK, then possible cause is vibration in plant near MES meters. Install flowmeters away from vibration causes, or anchor meters with rubber mounts.
- 4 If after batch complete and the **shut off valve fails** to close, then "backflow" alarm will engage.
- 5 If vibration is still prevalent, then using MES-R Reed Switch flowmeter pulseheads is recommended.
 - The **MES-R pulsehead is GREEN in colour with a square junction box** (2 wire connection) - this distinguishes them from the ordinary MES black/white round junction pulseheads.

See installation and programming instructions below, in particular that reprogramming of the ME2008 is required because an MES20-R 20mm size gives 61 pulses/Litre instead of 1000 pulses/Litre.

New MES-N pulseheads with new all solid state smart technology (frwd/rvrse flow) are vibration free and interchangeable with old style pulseheads.

MES-N INSTALLATION and PROGRAMMING

- A Replace MES pulsehead with a NEW MES-N vibration free pulsehead. Same as before 1000ppl



TROUBLESHOOTING GUIDE

Alert on the LCD display/Alarm	Possible Cause	Remedy
"Low Flow"	-Flow Rate below setting -Pulse Fail due to flowmeter failure -Airlock in <u>flowline</u>	-Check "Min. flow" value -Check flowmeter, and pulse cable wiring -Check delivery line -Check for line restriction
"High Flow"	-Flow Rate above Max.-Flow setting	-Check "Max. flow" value, has been exceeded -Check gate valve, restrict if necessary
"Output Overrun"	-Higher pulse rate than pulse out Hz (frequency) maximum setting (AC=15Hz, DC=35Hz).	-Check "Max Out Rate" value -Adjust pulse output value resolution -Check Flow Rate, restrict the gate valve.
"Over Dose"	-Dose Limit exceeded during batch	-Check "Dose Limit" (batch limit) value -Check PLC/Computer Settings
"Back Flow"	-Backflow of liquid after batch complete -Or excessive vibration at flowmeter install -Stuck external contactor/pump.	-Check Non-return valve, clean or replace. -Eliminate vibration source or use MES-R contact closure flowmeters. *see also Troubleshooting-Backflow on next page -rare case continuous backflow is external stuck contactor/pump running. kill power, replace contactor/pump or ME2000 drive relay stuck. <u>ME2020 when introduced should differentiate.</u>
"Diff Flow" (where used)	-Flowmeter Percent difference 5% exceeded (when comparator function is used)	-Check flowmeters (see comparator function explained)
"Setting Lost"	-Power Surge or major power loss to systems	-Check power supply/source -Use handheld programmer to reset the system and re-enter the parameters.

Or short the 2 pins as shown



To re-enable the module showing "settings lost", proceed as follows:

- Plug the hand-held Programmer into the Dual Channel Module;
- To restore the default settings (which are input calibration 1000 pulses/Litre, divided pulse output 10mls/pulse), push 2 buttons simultaneously on the Programmer, being either the 2 arrow buttons or the DOWN and UP buttons;
- Re-enter parameters (via the Programmer) and refer to program sheet settings.

2/ New MES-N pulseheads with new all solid state smart technology (frwd/rvrse flow) are vibration free and interchangeable.

- Computer may have leaky Optos. On computer batching system, the installing electricians:
 - must measure, on the batching computer, the leakage voltage (when a batch is NOT in progress) **between each black Opto's start 240v Active and Neutral.**
 - If the leakage > 50 volts ac, then resistor (about 12 KΩ to 15 KΩ, 10 Watt) must be installed to each Opto on the batching computer to drain the leakage to Neutral.
- Otherwise, a relay activated by 240 vac could still be held on by 90-110 vac leakage and, consequently, pumping will not stop until the maximum batch limit (as set on Batch Controller or ME2000) is reached, and an **overdose of admixture will occur.**

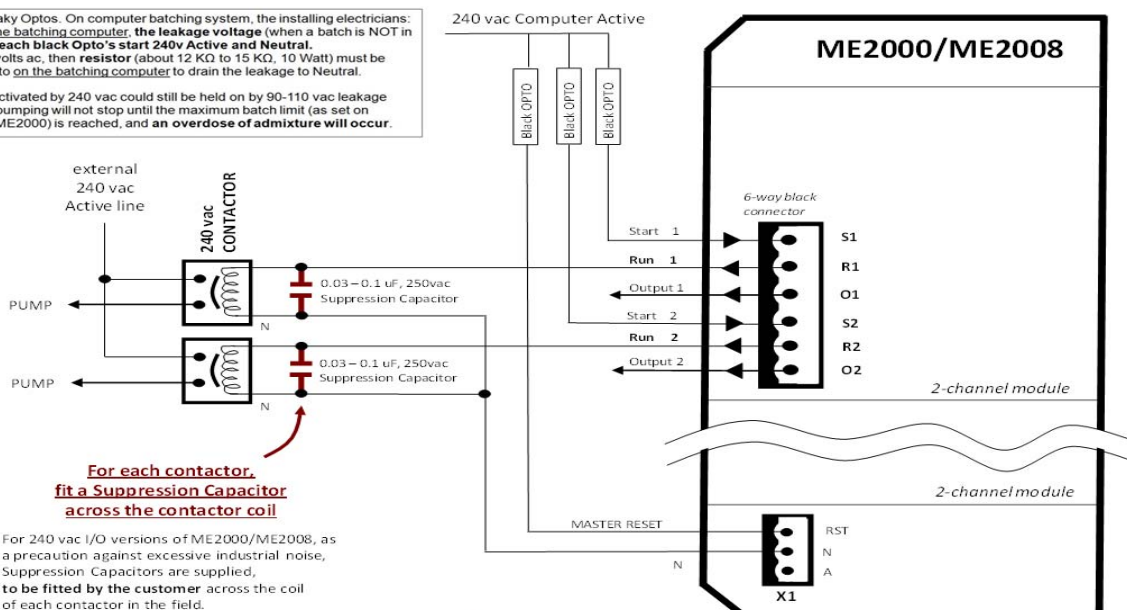

Fitting Suppression Capacitors to prevent electrical noise, and Resistors to prevent voltage leakage

MES larger meters INSTALLATION and PROGRAMMING

- A. Replace MES body.
- B. Program the ME2008 Input Pulse to suit the K-factor
- C. Change other program factors to suit flowmeter/appl. specs.
- D. **VERY IMPORTANT**

After replacement & programming of a flowmeter, take a calibration test before leaving the plant.

ME2008 DISPENSER INTERFACE **IN CASE OF ALARM WARNING:-**

- If any of the safety features are triggered, the alarm will sound.
- The Display will indicate message status condition of the channel that is in alarm condition, as a precaution the ME2008 will shut down pump drive
- of the faulty channel only, allowing further examination of the problem.
- **DO NOT** push RESET immediately - observe display and take note of the batch readings and the alarm message.
- **WAIT** for other channels to complete batch, then push RESET to be ready for the next batch.
- If batcher gets an Alarm again at batching, then:
- **MOVE THE TRUCK MIXER AWAY FROM THE LOADING POINT**
 - stop using that chemical channel; as each attempt doses 2 seconds worth of chemical into the mix.
 - record the quantity displayed on the ME2008 and the batch computer; and ring your local admixture supplier for advise/service.

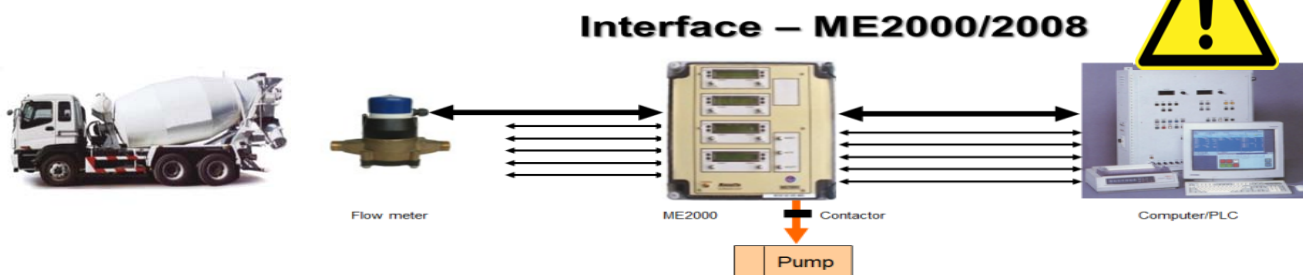

If in doubt, call your local installer / Admix Supplier or contact ManuFlo on phone +61 2 9938 1425 or +61 2 9905 4324.