

# **ME697** INTERFACE CARD (Jonel version)

## **FLOWMETER (MES20) TO JONEL COMPUTER PULSE COUNTER INTERFACE CARD with manual batch facility and pulse fail safety.**

### **FEATURES:**

- 6x 8 digit LCD counters, displayed in millilitres.
- Supports up to six MES20 flowmeters.
- Optional variable pulse dividers.
- 5 VDC pulse outputs with LED indication.
- Provides important cross-reference batch figure.
- Pulse Fail and Batch Limit safety override with LED warning indicators and alarm.
- 6 channel override batching facility.
- Easy plug-in connectors.
- Compact housing.

**ManuFlo**™  
Flow Measurement Products

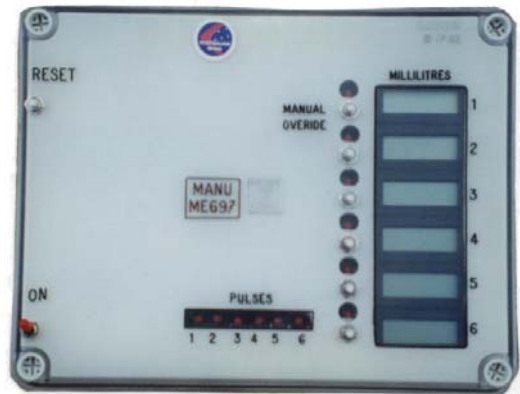

### **INTRODUCTION**

The ME697 counter divider interface card was designed to act as a support product in interfacing upto six Manu admixture 20mm pulse output flow meters ( MES20, KGG20, MEK20 ) with Jonel and other USA industrial computer systems, requiring low frequency pulse rates and 5 VDC pulse inputs. This new design incorporates new high resolution missing pulse and maximum batch limit overrides, as well as a six channel manual batching facility.

### **FUNCTION**

The computer system provides an AC output start and hold drive signal (black Opto22) to ME697 start input. The ME697 output drive supplies power to external contactor coils driving pumps and/or solenoids. ME697 supplies +12VDC to flowmeters which in turn send back pulses, these are counted by individual channel LCD displays in millilitres. The pulses are then sent to the computer inputs (white Opto22). When the computer system has OPTO22, 5 VDC input optos, incoming pulses are limited to 14 Hz maximum. Due to high resolution pulsing of flowmeters, the pulse rates must be divided. The onboard selectable dip switches are then set to the desired pulse division rate (see Fig.1).

The output pulses are indicated by the pulse LEDs. The pulses are transmitted via a Motorola 4N33 opto to the 5 VDC computer input card (White OPTO22). When computer has completed batch cycle, a 240 vac reset signal is supplied to the ME697 master reset relay, thus resetting all counters.

### **SAFETY OPERATION**

If at any time during batch cycle, any flowmeter stops pulsing (e.g. due to flow obstruction, failure, blockage, pump failure etc), or the preset upper safety limit is reached, the inbuilt Pulse Fail feature will activate, shutting down flow regardless of computer's status operation. If Pulse Fail (P.F.) is activated, warning LED(s) will illuminate, indicating the channel at fault. Also, an audible alarm will sound. If upper batch limits are set, and if they are reached, the same safety features will activate. If a channel(s) pulse failed, remember the quantity displayed. Reset unit to resume batching.

**Order Code for ME697 for Jonel Computer: ME697-1A-2A-3A-4B-5A (see Page 7)**

## ME697 (Jonel version)

**OPERATION** To batch in manual mode (without computer) :

- Switch **on** power. Reset or zero counters by pushing the **reset** button.
- Push and hold one (or more) of the six **run** buttons. When the desired amount is reached, release button. You can also batch from the computer's manual mode at console panel.
- When batching automatically (computer mode), do not touch **reset** or **run** buttons.
- If alarm activates, always cross-reference ME697 and computer screen displays to see if they are corresponding in the quantity dispensed.



\*\*\*\*\*  
 If Pulse Fail (P.F.) occurs repeatedly and alarm sounds, do not persist - qualified service or advice is required.  
 \*\*\*\*\*

**INSTALLATION**

1. Find a suitable position to wall mount box, consider good view of LCDs and room for wiring. The ME697 is fixed to the cover lid, therefore cable gland entries can be fitted to box at any location.
2. Use at least a 10-core shielded cable for flowmeters. Wire flowmeter cable to 8-pin (J4) flowmeter input plug, taking care to observe correct channel (1-6) identification, and that wiring to + and - terminals is correct.
3. Connect 240vac supply to 3-pin plug (J5).
4. Connect from 7-pin plug (J1), the 5 VDC pulse output drives to computer's White OPTO22 pulse inputs.
5. Connect from 8-pin (J2) input start and master reset plug, to 6 x computer's PLC output start drives and 1 x master reset drive located in computer I/O panel.
6. Wire from 7-pin plug (J3) output drive plug, to external contactor coil and/or solenoid flow control drives.

Make sure only one common active line and neutral is used to interconnect wiring on ME697 card, from the computer supply. Do not mix active pump drive with computer's Uninterruptable Power Supply (UPS).

NOTE: Neutral J2 & J5 is already bridged internally.  
 J5 active line after switch and fuse is bridged to J3 Active. Only wire A.N.E. J5 power input plug.  
 \* Six wires from J1 to computer White OPTO22 (pulses)  
 Seven wires from J2 to computer black OPTO22 (six start drives, one master reset).  
 From J3, six wires will drive each contactor coil, return neutral to J2 neutral.  
 From J4, wire six pulse wires, one +12V, one O.V. or shield to flowmeters.

<p><b>SPECIFICATIONS</b></p> <p><b>Display:</b> 6 x 8 digit LCD counters in millilitres</p> <p><b>Power supply:</b> 220-260 vac (optional 110 vac)</p> <p><b>Supply to flowmeters:</b> 12 VDC (10mA per flowmeter)</p> <p><b>Pulse inputs:</b> Up to 6 x MES20 flowmeters (1 millilitre per pulse) max. 1kHz</p> <p><b>Computer pulse outputs:</b> 5 VDC</p> <p><b>Computer start/reset:</b> 240 vac via relays (11KΩ coil) - 110 vac optional</p> <p><b>Output starts:</b> 240 vac via relays - 110 vac optional (requires contactors to drive pumps)</p> <p><b>Pulse fail:</b> Triggers below (adjustable) 25Hz (25 mls per sec flowrate) with LEDs illuminated.</p> <p><b>Preset batch limits:</b> 640 to 51200 ml. max. or infinite. Selectable via 4-way DIP.</p> <p><b>Optional pulse division:</b> ÷10, 20, 50 or 100 (mls per pulse). Selectable via 4-way DIP.</p> <p><b>LED output pulsers:</b> Blinks at divided pulse rate (e.g. 100mls)</p> <p><b>Manual batch start:</b> Via 6 x momentary push buttons.</p> <p><b>Connectors:</b> Plug-in J1, J2, J3, J4, J5</p> <p><b>Enclosure:</b> IP55 wall mount 225L x 180W x 90D</p> <p><b>Weight:</b> 1.5 kg</p>	<p style="text-align: right;"><b>RED DIP</b></p> <p><u>Pulse Division settings</u>              To set division rates slide up pins to ON.</p> <div style="text-align: center;">  </div> <table style="width: 100%; border: none;"> <tr> <td style="width: 50%;">1 ON only</td> <td style="width: 50%;">+10 (10mls./pulse)</td> </tr> <tr> <td>2 ON only</td> <td>+20 (20mls./pulse)</td> </tr> <tr> <td>3 ON only</td> <td>+50 (50mls./pulse)</td> </tr> <tr> <td>4 ON only</td> <td>+100 (100mls./pulse)</td> </tr> </table> <hr/> <div style="text-align: center;">  </div> <p style="text-align: right;"><b>BLUE DIP</b></p> <p><u>Limit x Divided Pulse</u></p> <table style="width: 100%; border: none;"> <tr> <td style="width: 50%;">4 ON only =</td> <td style="width: 50%;">64 x PulseDiv</td> </tr> <tr> <td>3 ON only =</td> <td>128 x PulseDiv</td> </tr> <tr> <td>2 ON only =</td> <td>256 x PulseDiv</td> </tr> <tr> <td>1 ON only =</td> <td>512 x PulseDiv</td> </tr> </table>	1 ON only	+10 (10mls./pulse)	2 ON only	+20 (20mls./pulse)	3 ON only	+50 (50mls./pulse)	4 ON only	+100 (100mls./pulse)	4 ON only =	64 x PulseDiv	3 ON only =	128 x PulseDiv	2 ON only =	256 x PulseDiv	1 ON only =	512 x PulseDiv
1 ON only	+10 (10mls./pulse)																
2 ON only	+20 (20mls./pulse)																
3 ON only	+50 (50mls./pulse)																
4 ON only	+100 (100mls./pulse)																
4 ON only =	64 x PulseDiv																
3 ON only =	128 x PulseDiv																
2 ON only =	256 x PulseDiv																
1 ON only =	512 x PulseDiv																

Due to continuous product improvement, specifications are subject to change without notice.

## **ME697 Troubleshooting**

- keep the input rate to DC Computer/PLC below the maximum scanning time of the PLC or input optos (e.g. 15 Hz)
- if the ME697 appears disabled (e.g. displays read zero, does not count, no functions even in manual mode) then the Master Reset black Opto on the PLC is leaking, or is stuck on causing a continual reset drive to the ME697. Measure the leakage voltage between the Master Reset (Connector J2, pin 7) and Neutral (Connector J2, pin 8). If there is more than 60vac voltage, then:
  - replace the Black Optos; and/or
  - fit a 12-15 K $\Omega$  10W resistor between the Master Reset and Neutral (i.e. between pins 7 and 8 of Connector J2). If there is still a problem, then it is a Computer issue that the master reset is stuck on. Disconnect the plug connecting the Computer to J2 and batch manually.
- if the batching computer's black Optos are leaky (i.e. there is more than 60vac residual voltage after Opto latches off, which could cause batching to continue because the ME697 relay is being held on), then:
  - replace the Black Optos; and/or
  - fit a 12-15 K $\Omega$  10W resistor between each black Opto's Active 240vac Computer Start (i.e. relevant pin on connector J2) and Neutral (pin 8 on Connector J2).
- if experiencing slow counts on one channel after batch completes: ensure that Check Valve is not faulty.
- if experiencing phantom counts on one channel: check wiring and shield.
- if experiencing constant phantom counts on many channels: the internal 1000  $\mu$ F electrolytic capacitor may have failed, so return the ME697 to ManuFlo for service.

# INSTALLATION GUIDE for ME697 Interface Card with MES20 and other flowmeters

(1) Locate the most appropriate position to mount the MES20 flowmeter. Preferably:

- your site's flowmeters should be grouped together off the ground on a stand.
- protect the flowmeters from the elements by using a cover, which should be lightweight with handles for easy access by service personnel.
- a vibration free area is recommended, as the MES20 is sensitive to high vibrations which can cause some stray pulses (see the "Installation" section in the MES product brochure).

(2) Establish the outlet point position in relation to the storage tank:

**2a) If the outlet point is above the top of the storage tank (the most commonly used setup),** then the equipment you will need is at least: a pump, non-return valves or spring loaded check valves (12psi), flow restriction gate or ball valve, a flowmeter with pulse output and, optionally:

- a solenoid valve (air-assisted ball valve type) for instant shut off of flow, recommended to prevent the Venturi effect when injecting into water lines, but may not be required if the installation has reasonable head height.
- a 3-Way Valve to provide an easily accessible calibration point.

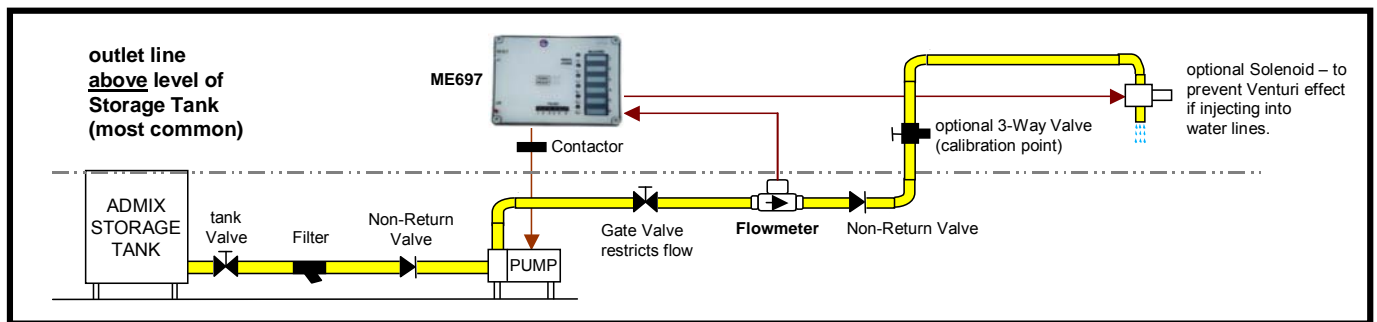

**2b) If the outlet point is at the same level as the storage tank,** then the equipment you will need is at least: a pump, a flow restriction gate or ball valve, a flowmeter with pulse output, and a solenoid valve to stop free flow.

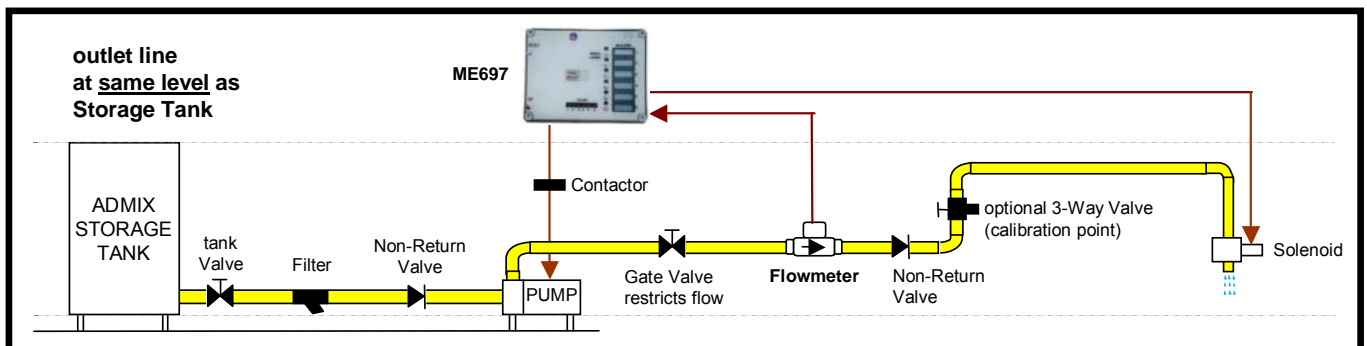

**2c) If the outlet point is below the level of the storage tank,** then the equipment you will need is at least: a flow control solenoid valve, a flow restriction gate or ball valve, and a flowmeter with pulse output.

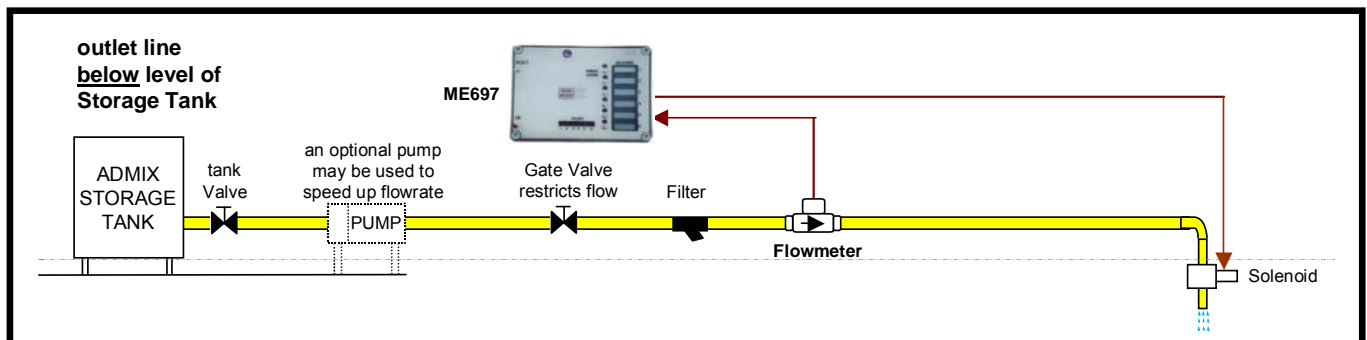

## SELECTION OF PIPE LINE DIAMETERS

(MES20 20mm flowmeter)

For low flowrates and small batch quantities of liquid (approx. <2000mls., use 1/2 inch diameter pipe or hose (after the flowmeter). For medium to high flowrates use 3/4 to 1 inch diameter pipe.

For very high flowrates use 1 1/4 inch. NOTE:- Pipeline can be flexible reinforced hose, rigid PVC or metallic.

Warning: Running flowmeters over their maximum flow rating can cause damage & overdosing.

For other flowmeters 25mm, 40mm etc., use same diameter size as meter size or slightly larger diameters for specific gravities of 1.2 & greater.

## PUMP SELECTION

When 20mm MES20 flowmeters are used with fluids of spec. gravity 1 to 1.35, use centrifuge pumps 0.5 to 1 horse power (e.g. 1" Onga 413 or Davey pumps), a flowrate upto 0.8 litres per second can be achieved, depending on head height. For higher density fluids gear pumps or other types of positive displacement pumps are more suitable. Because of pressures generated by gear pumps it is important that restriction of flow be achieved with bypass of inlet to outlet flow valve or recirculating flow line.

When using larger capacity flowmeters, a proportionally larger pump will apply.

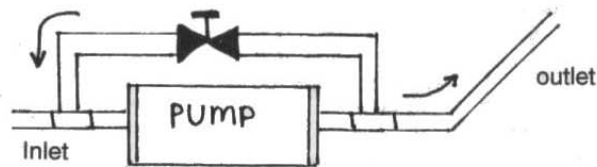

## FILTERS

A considerable amount of foreign particles can be transferred into admixture storage tanks. Therefore it is advisable to install a box filter prior to positive displacement type flowmeters, preventing possible blockage or damage to flowmeter measuring chamber.

(A Ystrainer filter with 500micron mesh recommended).

## COMMISSIONING FLOWMETER / ME697 INTERFACE CARD SYSTEM(S)

Electricians must refer to the relevant system wiring diagram. Mount the ME697 interface card on a suitable panel or near the computer/PLC input panel.

When wiring the flowmeter(s), use shielded cable. For example when wiring 6 flowmeters in the one installation, use atleast 10 core shielded cable. One core for each pulse wire and atleast one core for the positive +12VDC voltage supply linked to each flowmeter, and one core coupled with the shield as O.V. For Input/Output drive wiring consult the ME697 brochure and relevant wiring diagram.

All pulse inputs to ME697 are 1 ml per pulse and are counted on the LCD displays.

Select the appropriate divider pulse ratio settings for each channel, via the red color 4 way DIP switches. (Make sure the divided pulse value corresponds with the computer software input parameter, e.g. divide by 100 is 100 mls per count input).

Now select the override limit settings, via the Blue color 4 way DIP switches.

Power up the system. Prime the admix line, until liquid appears at outlet line, ME697 card's pulse LED is blinking and the LCD counters should count.

A volumetric calibration test must be performed when commissioning a new installation, and a followup atleast bi-yearly test. A calibrated vessel is placed near the sok (or at a access point after the flowmeter and non-return valve), using the manual batch buttons, batch a small volume. Check the display and the volume collected - they should match. Then select a batch quantity with computer, all should match.

(example: 10.1 litres called on batch computer, 100 millilitres per pulse set on ME697 divider, 10.1 litres of admixture collected in vessel, 101 counts on computer screen, 10100 mls on ME697 display - correct result.

JONEL 5V dc SINK Logic pulse Model

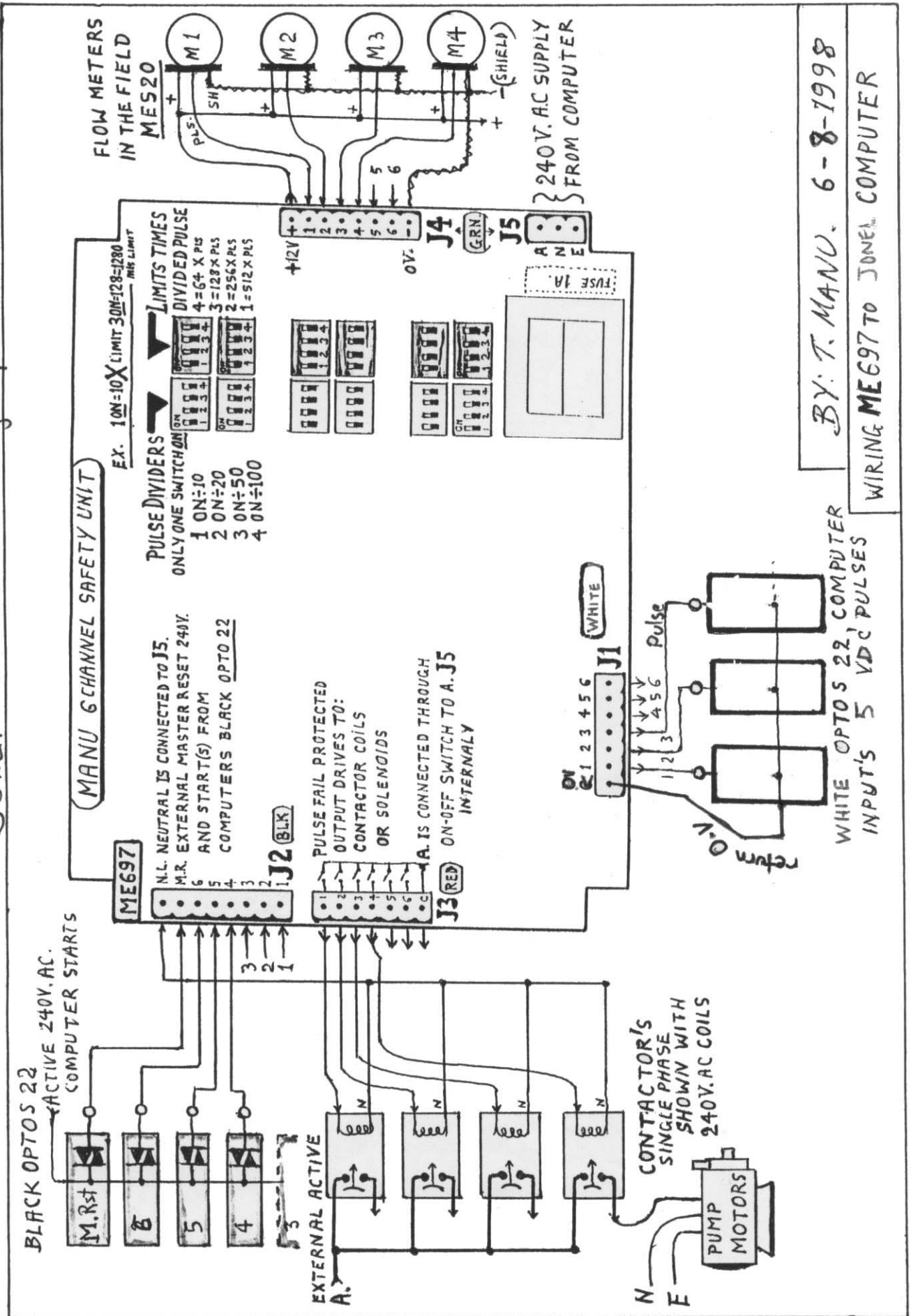

BY: T. MANU. 6-8-1998  
WIRING ME697 TO JONEL COMPUTER

**ME697 Order Code Options**

When ordering ME697 card, add the codes to indicate which specification options are required to suit your PLC/Computer/IO control card and external contactors/coils.

e.g. Order Code for ME697 for Jonel Computer: ME697-1A-2A-3A-4B-5A

**ME697**                      6-channel flowmeter-to-PLC/Computer interface card,  
with safety and manual batch facility.

**POWER SUPPLY (to card)**

-1A                      240 vac power supply  
-1B                      110 vac power supply  
-1C                      24 vac power supply  
-1D                      24 VDC power supply

**START INPUT DRIVES and MASTER RESET (from Computer starts)**

-2A                      240 vac power supply  
-2B                      110 vac power supply  
-2C                      24 vac power supply  
-2D                      24 VDC power supply

**START OUTPUT DRIVES (from ME697 to contactor coils and solenoids)**

-3A                      240 vac power supply  
-3B                      110 vac power supply  
-3C                      24 vac power supply  
-3D                      24 VDC power supply  
-3E                      OPEN CONTACT

**PULSE OUTPUT (to computer input)**

-4A                      24-240 vac triac pulse output switching  
-4B                      5-24 VDC 4N33 opto isolated pulse output switching (sink = pulse to O.V.)  
-4C                      5-24 VDC 4N33 opto isolated pulse output switching (source = pulse to +)

**PULSE DIVISION (to computer input)**

-5A                      standard dividers 10, 20, 50, 100  
-5B                      1 ml in, 1 ml out  
-5C                      SCC signal conditioner card fitted to nominated input channels  
(for flowmeters other than MES20).